

## Anwendungsfälle

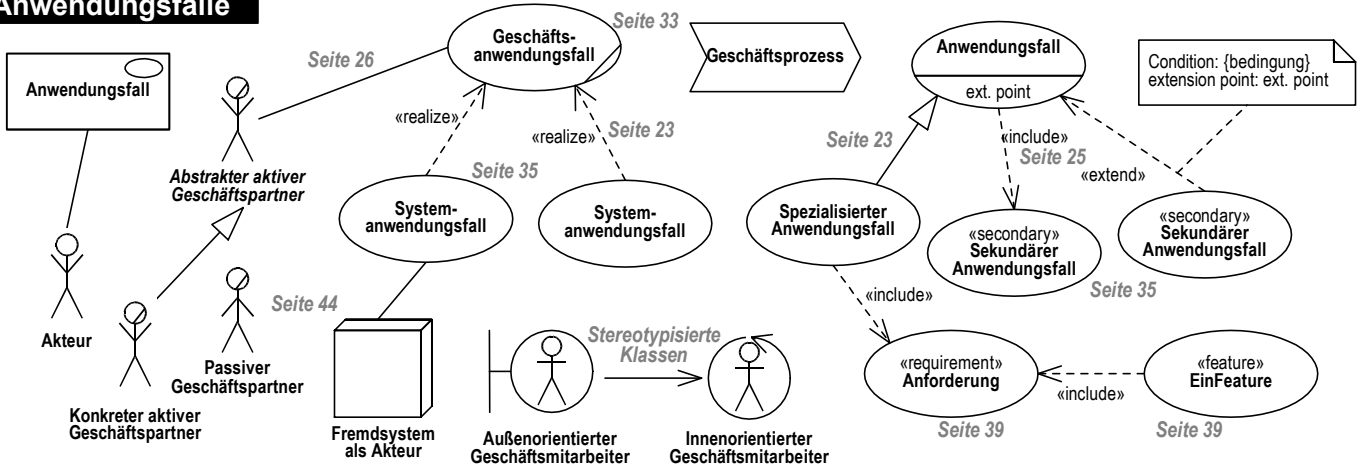

## Klassen und Objekte

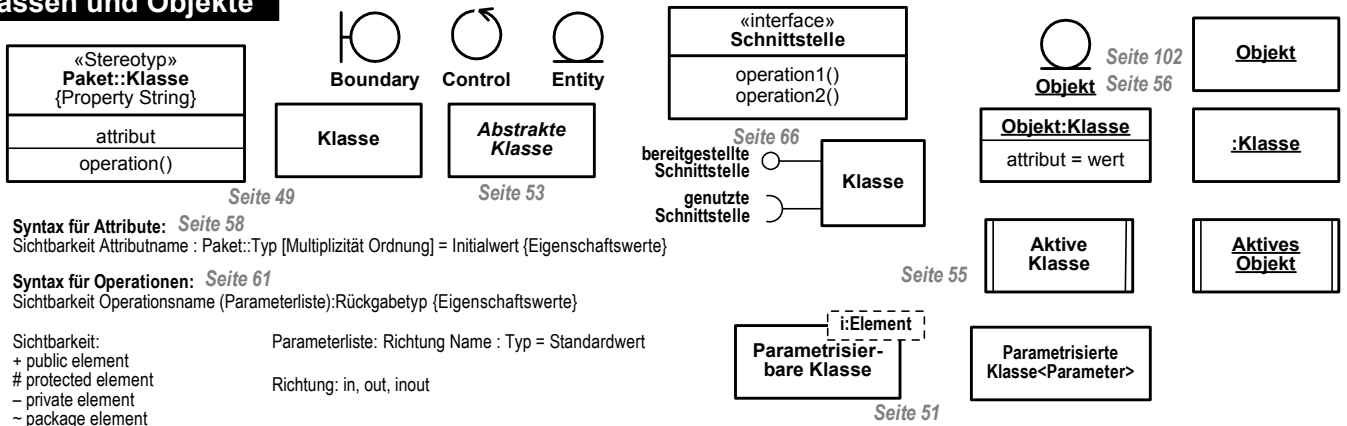

## Beziehungen

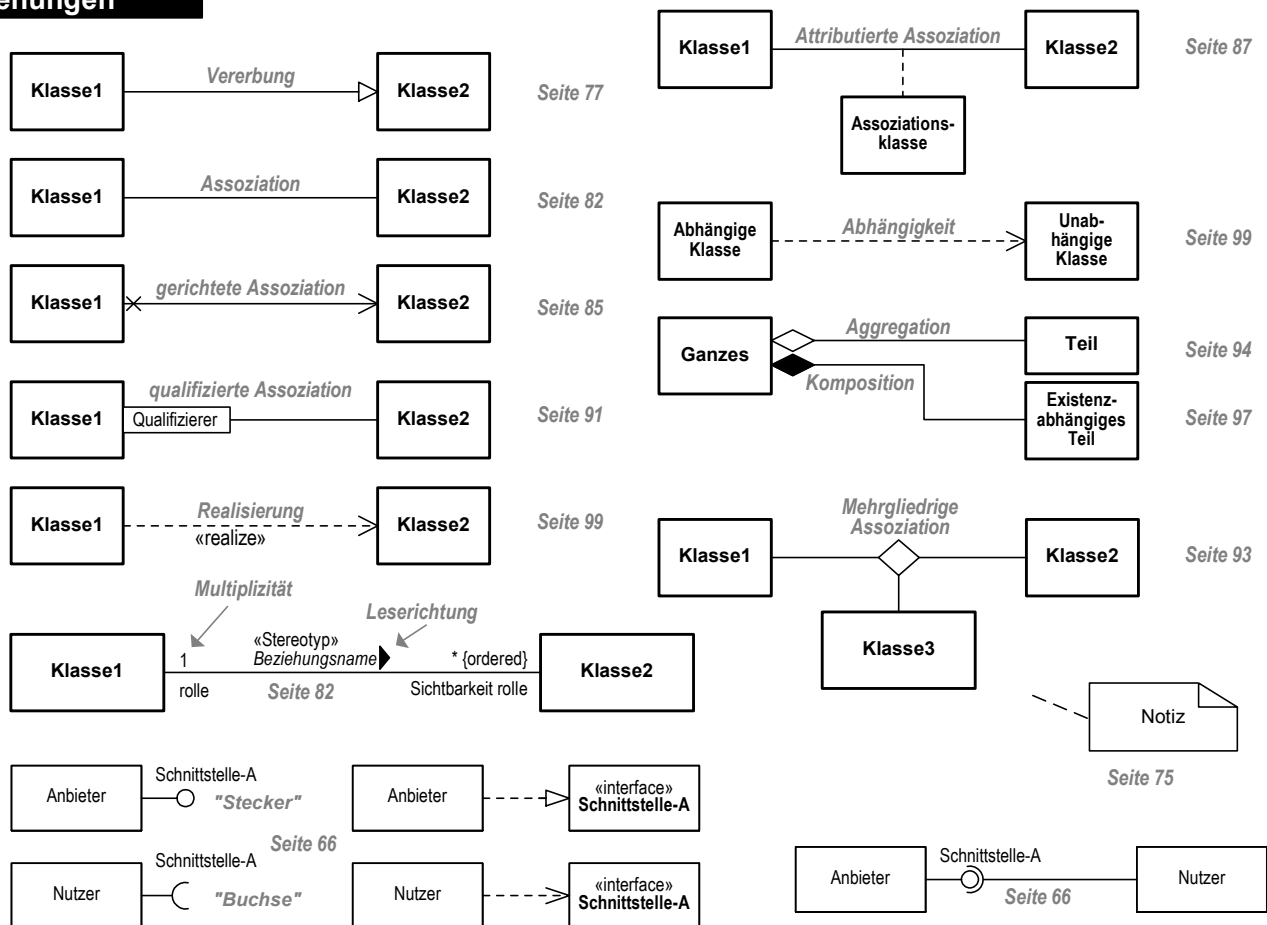

Die angegebenen Seitenzahlen beziehen sich auf "Die UML 2.0-Kurzreferenz für die Praxis", 3. Auflage, von Bernd Oestereich

## Pakete

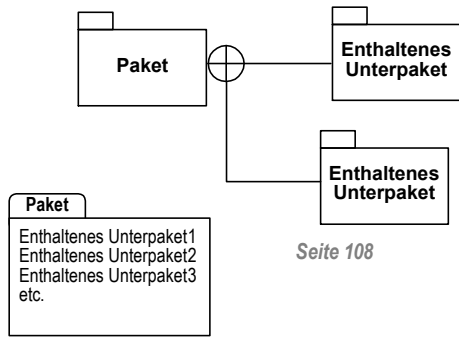

Seite 108

## Deployment

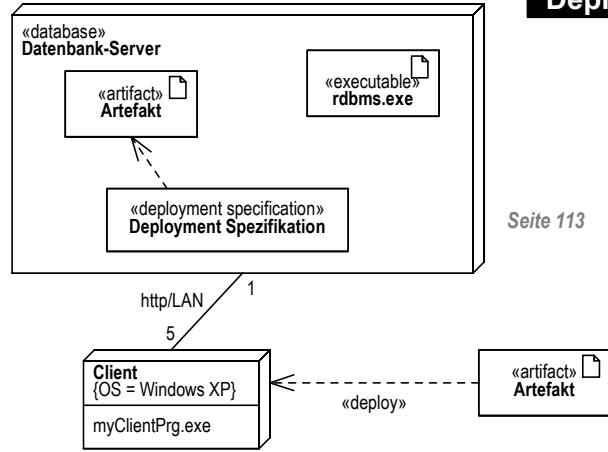

Seite 113

## Komponenten

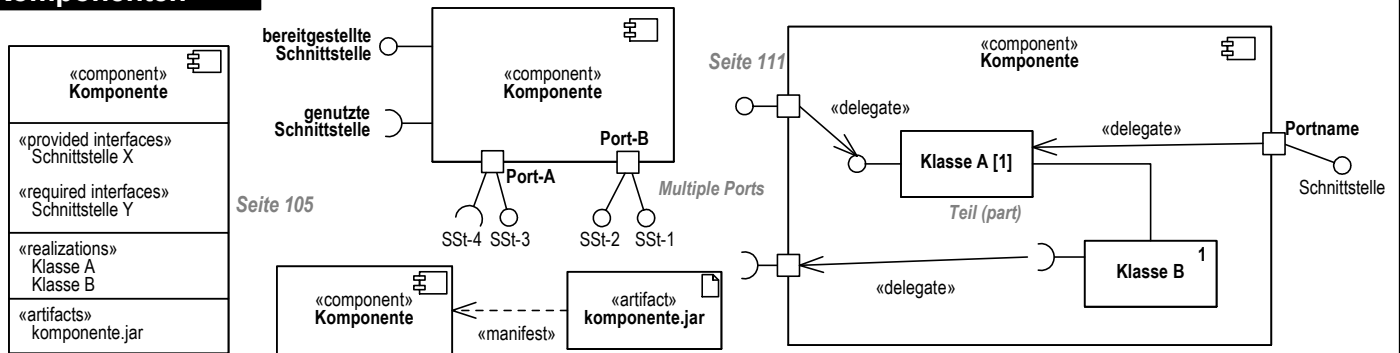

Seite 105

Seite 111

## Zustandsdiagramm

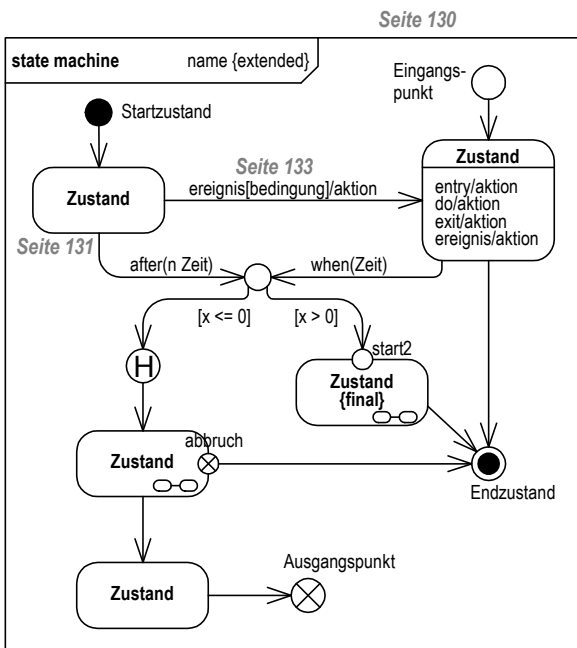

Seite 130

Seite 133

Seite 131

## Kommunikationsdiagramm

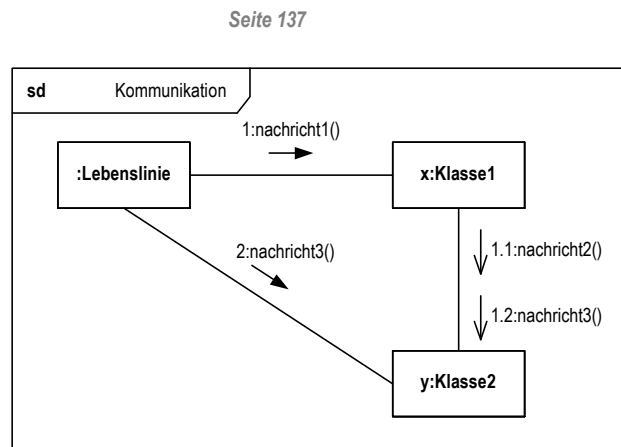

Seite 137

## Timingdiagramm

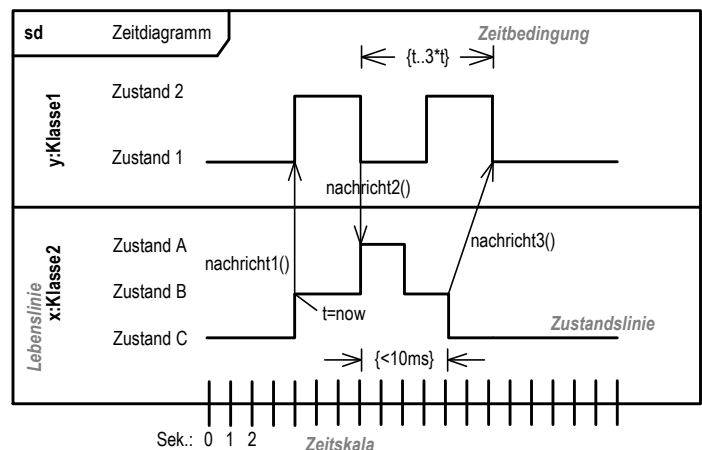

Seite 149

Die angegebenen Seitenzahlen beziehen sich auf "Die UML 2.0-Kurzreferenz für die Praxis", 3. Auflage, von Bernd Oestereich

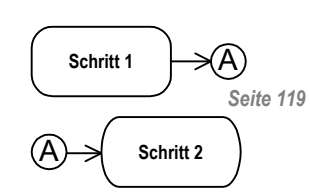
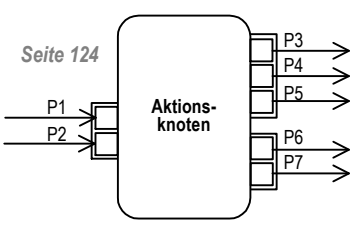
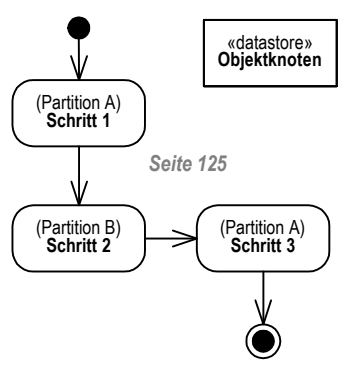
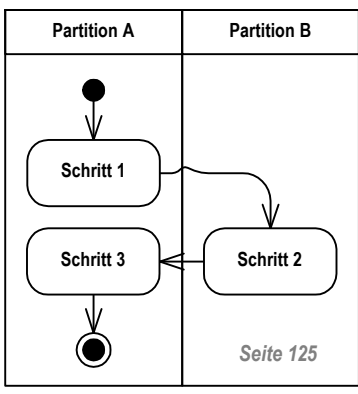
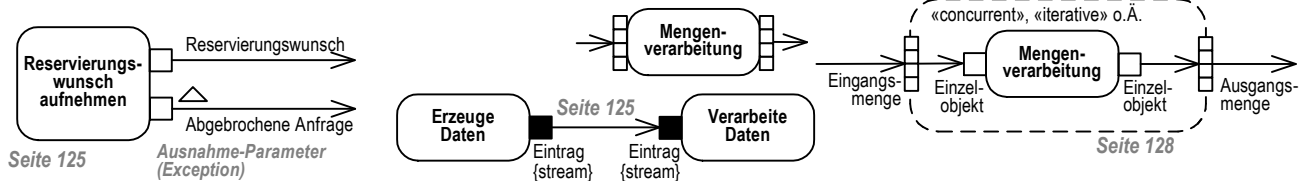
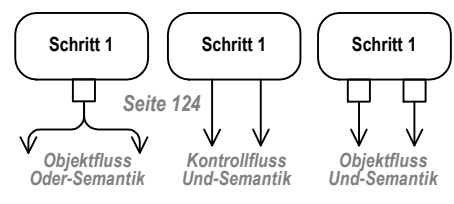
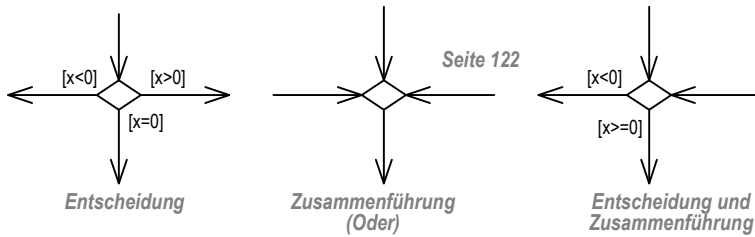
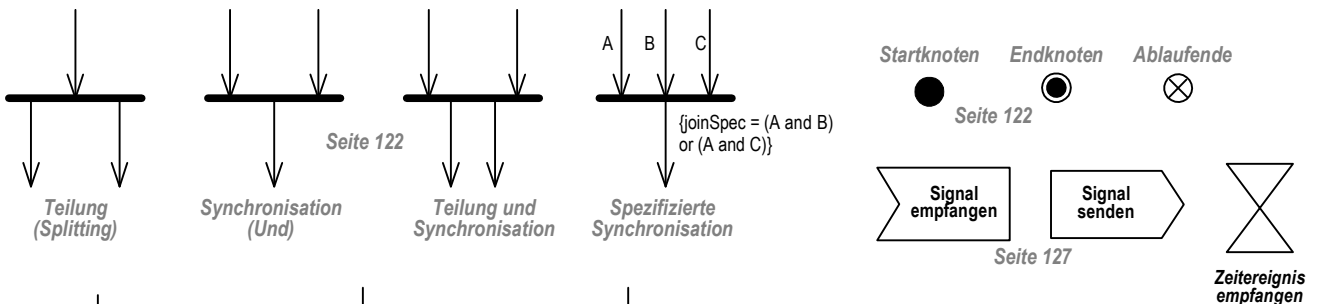
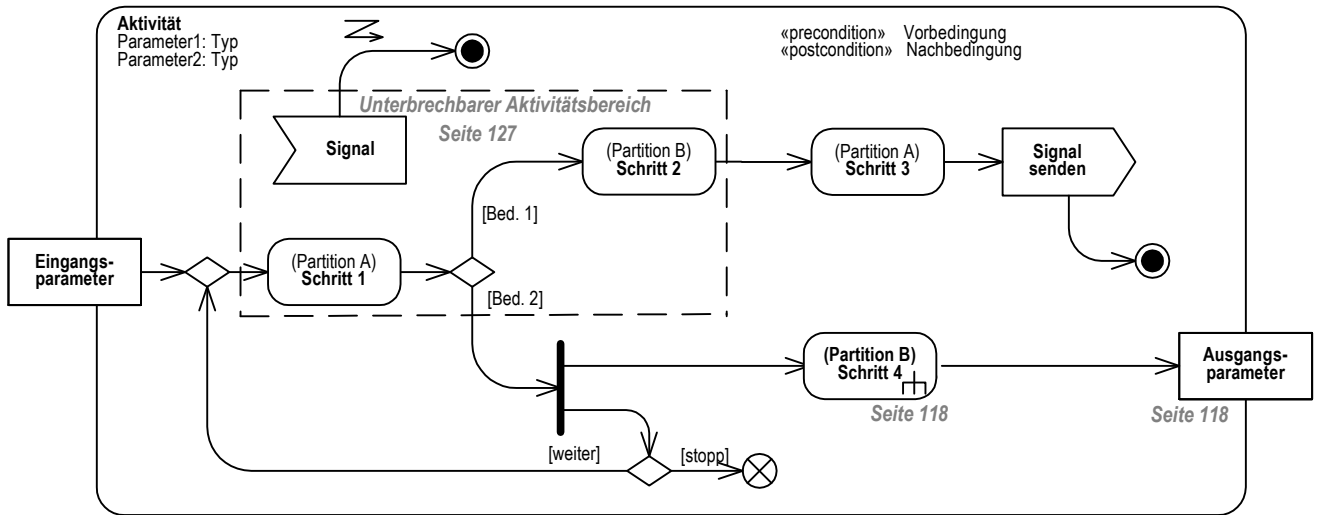

**Interaktionsübersicht**

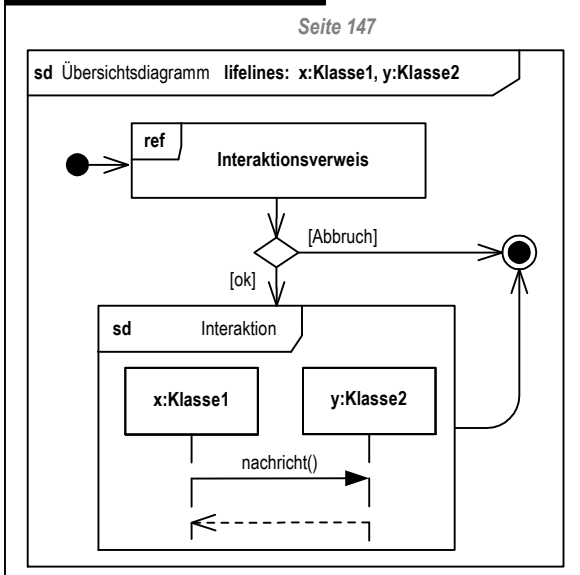

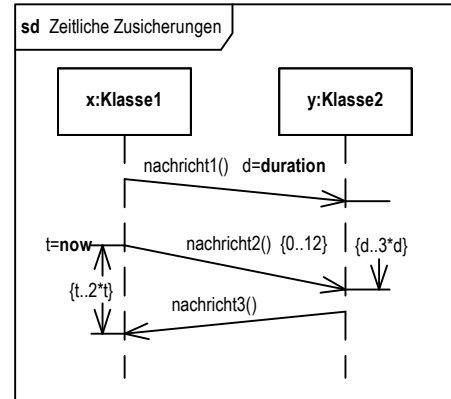
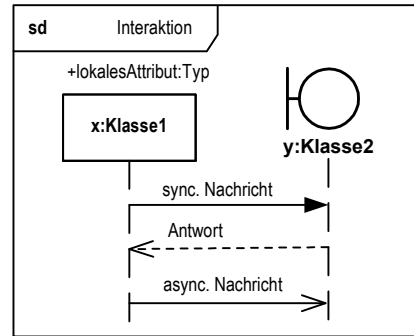
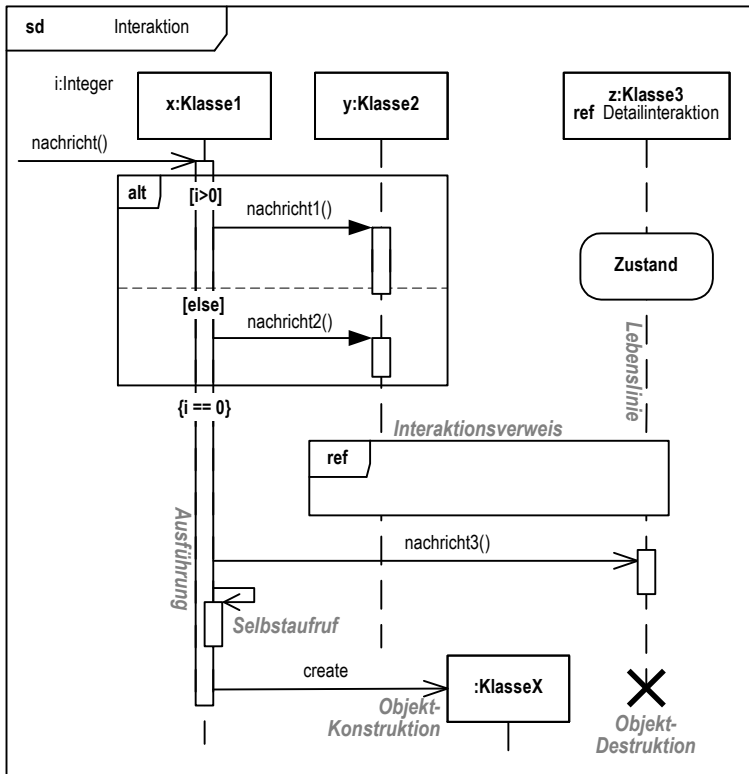

Diagrammübersicht

Die angegebenen Seitenzahlen beziehen sich auf "Die UML 2.0-Kurzreferenz für die Praxis", 3. Auflage, von Bernd Oestereich

